

**I-INT-HEX-EG M-Series Instrument Tray**

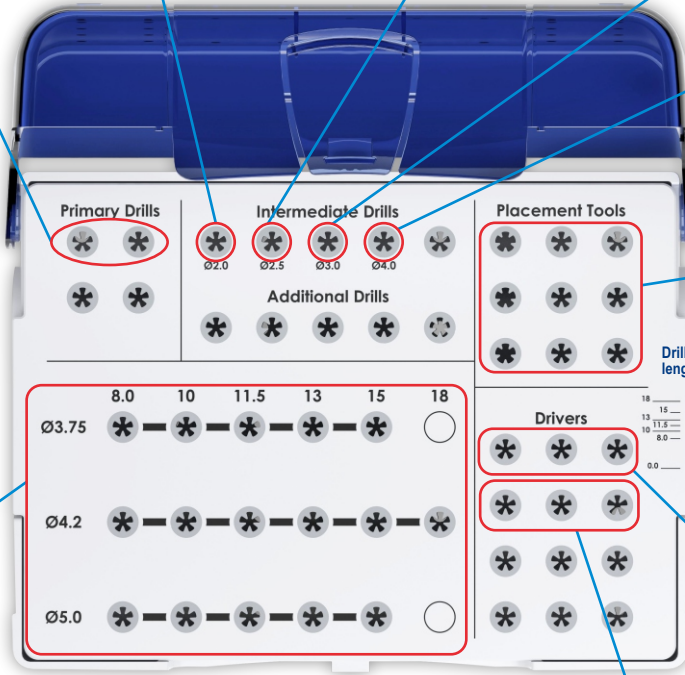

**Pilot Drills**  
D-3Spade-1.8M  
D-RB-MS  
D-12T-M15  
D-16-T

**Ø2.0mm Twist Drills**  
D-20T-M10  
D-20T-M15

**Ø2.5mm Twist Drills**  
D-25T-M15  
D-25T-M20

**Ø3.0mm Twist Drills**  
D-30T-M10  
D-30T-M15  
D-30T-M20

**Ø4.0mm Twist Drills**  
D-40T-M10  
D-40T-M15

**Dedicated Tapered Drills**

**Ø3.7**  
D-MT3708  
D-MT3710  
D-MT3711  
D-MT3713  
D-MT3715

**Ø4.2**  
D-MT4208  
D-MT4210  
D-MT4211  
D-MT4213  
D-MT4215  
D-MT4218

**Ø5.0**  
D-MT5008  
D-MT5010  
D-MT5011  
D-MT5013  
D-MT5015

**Insertion Tools**

I-HM-S / M / L  
Handpiece Insert

I-WI-M-S / M / L  
Wrench Insert

**Quad Drivers**

QUAD-S I-QDI-S/M/L  
Handheld

I-HQD-S/M/L  
Handpiece Insert

I-WI-QS/M/L  
Wrench Insert

**Universal 1.22/1.27 Hex Drivers**

HEX22U I-HD-22U-S/M/L  
Handheld

I-HHD-22U-S/M/L  
Handpiece Insert

I-WI-22U-S/M/L  
Wrench Insert

Images are for illustration purposes only and do not necessarily accurately represent the product. Not all products are cleared for sale in all countries.

# I-INT-HEX-EG M-Series Instrument Tray

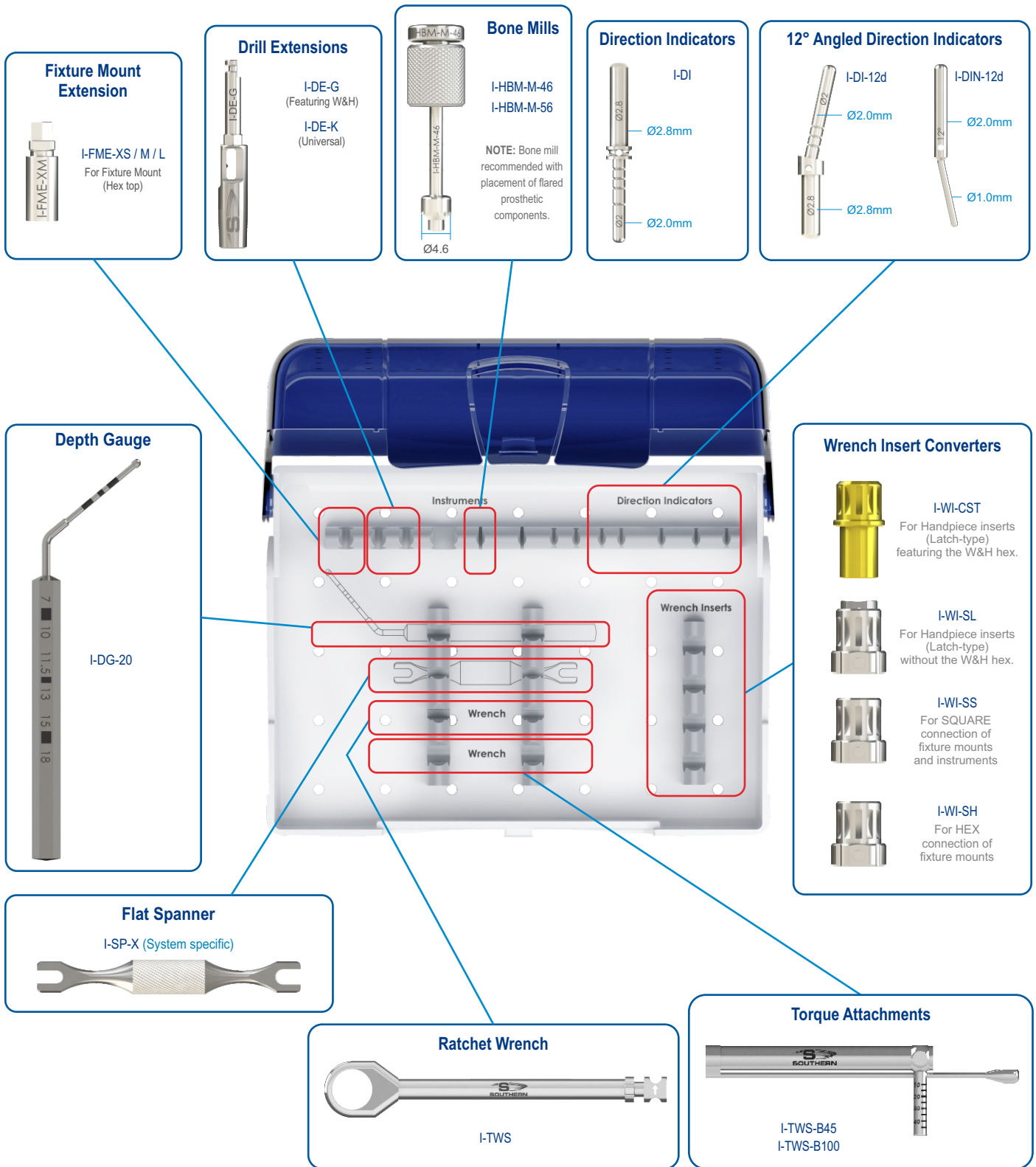

**NOTE:**

- The surgical kit has an intuitive layout to guide the surgeon through the drill sequence.
- Most Instruments available in Short / Medium / Long.
- All instruments and tooling used during the procedure must be maintained in good condition, and cleaned and sterilized prior to use. Please consult the Southern Implants Cleaning and Sterilization Procedure Guidelines (CAT-1039) for guidance concerning the maintenance of drills, instruments, and surgical trays.