

Intended use:

Southern Implants dental abutments are intended to be used in the Maxilla or Mandible for supporting a prosthesis on endosseous implants in order to restore chewing function for the patient.

Description:

These are pre-manufactured prosthetic components connected direct to an endosseous implant, for use as an aid in multiple unit prosthetic rehabilitation. The abutments are made of pure Ti or Ti-alloy (Ti-6AL-4V).

The Compact Conical Abutments are available in the Internal Hex, Deep Conical, Tri-Nex, IT, External Hex and Compact Conical connection interfaces. The abutments are available in regular (straight) as well as angled, 17° & 30°. (Angled Compact Conical Abutments are not available for all implant interfaces.) All Angled Compact Conical Abutments are supplied with a handle. Refer to individual product catalogues for product characteristics: M-Series (CAT-2043), DC (CAT-2042), Tri-Nex (CAT-2004), Provata (CAT-2060), IT (CAT-2005), External Hex (CAT-2020).

Indications for use:

Compact Conical Abutments non-engaging are indicated to provide support and retention for multi-unit screw retained restorations. Screw-retained restorations are designed to be screwed either directly onto the implant or onto an abutment positioned on the implant (Compact Conical abutment.) Screw retained restorations represent a secure and easy way to maintain a prosthetic restoration. Compact conical abutment is a pre-manufactured prosthetic component used in prosthetic rehabilitation in cases where it is desired to raise the prosthetic interface to a 'higher' level than the implant platform. Do not use angled compact conical abutment on Zygomatic or Oncology implants.

Contraindications:

- Do not use in patients:
- who are medically unfit for dental implant procedures.
 - who are allergic or have hypersensitivity to pure titanium or titanium alloy (Ti-6AL-4V).
 - where adequate numbers of implants could not be placed to achieve full functional support for a prosthesis.

Warnings:

- **THESE INSTRUCTIONS ARE NOT INTENDED AS A SUBSTITUTE FOR ADEQUATE TRAINING**
- For the safe and effective use of dental implants it is strongly suggested that specialised training be undertaken, including hands-on training to learn proper technique, biomechanical requirements and radiographic evaluations.
- Responsibility for proper patient selection, adequate training, experience in the placement of implants, and providing appropriate information for informed

Images are for illustration purposes only and do not necessarily accurately represent the product.

consent, rests with the practitioner. Improper technique can result in implant failure, damage to nerves/vessels and/or loss of supporting bone.

Cautions:

- New and experienced Implant users should do training before using a new system or attempt to do a new treatment method.
- Take special care when treating patients who have local or systemic factors that could affect the healing of the bone and soft tissue. (I.e. poor oral hygiene, uncontrolled diabetes, are on steroid therapy, smokers, infection in the nearby bone and patients who had oro-facial radiotherapy.)
- Thorough screening of prospective implant candidates must be performed including:
 - A comprehensive medical and dental history.
 - Visual and radiological inspection to determine adequate bone dimensions, anatomical landmarks, occlusal conditions, periodontal status, and adequacy of bone.
 - Bruxism and unfavourable jaw relations must be taken into account.
- Proper pre-operative planning with a good team approach between well trained surgeons, restorative dentists and lab technicians is essential for successful implant treatment.
- Small diameter implants are not recommended for use in the posterior region of the mouth.
- Minimizing the trauma to the host tissue increases the potential for successful osseointegration.
- Electro-surgery should not be attempted around metal implants, as they are conductive.
- Care must be taken that parts are not swallowed during any of the procedures, thus rubber-dam application is recommended when appropriate.
- Care must be taken to apply the correct tightening torque of abutments and abutment screws.
- Regular patient follow-up, and proper oral hygiene must be achieved are essential for favourable long-term results.

Procedure for use:

First Clinical procedure:

Straight Compact Conical abutments:

1. Select and connect appropriate abutment to the implant, using the abutment driver (I-AD).
Follow – steps 2 - 5

Angled Compact Conical abutments: (17° & 30°)

1. Place the abutment screw in the abutment prior to bringing it to the implant. (It is not possible to seat the abutment on top of the implant and thereafter to introduce the abutment screw.)
For Angled Compact Conical abutments (17° and 30°) use handle (supplied with the abutment), to position the abutment about 2mm above the implant. Screw the abutment screw into the implant until the abutment is pulled down to about 1mm above the implant (refer to figure below). Now seat the abutment down on the implant.

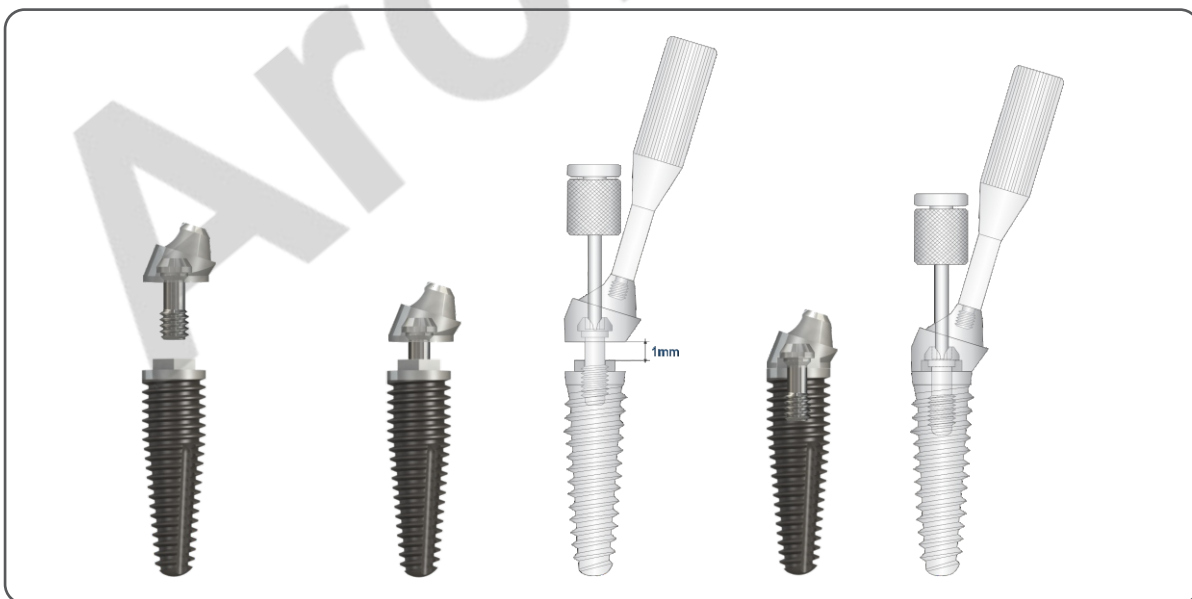

2. Verify the correct seating of the restoration using radiographic imaging. Tighten to required torque with the appropriate driver and torque wrench. Caution; never exceed the recommended torque as overtightening may lead to screw fractures.
3. Connect impression copings to the Compact Conical Abutments.
4. Take an open or closed tray impression and remove/transfer the impression copings to the impression.
5. Connect the healing cap or temporary restoration direct to the compact conical abutments.

Laboratory procedures

1. Attach abutment analogues to impression coping in the impression.

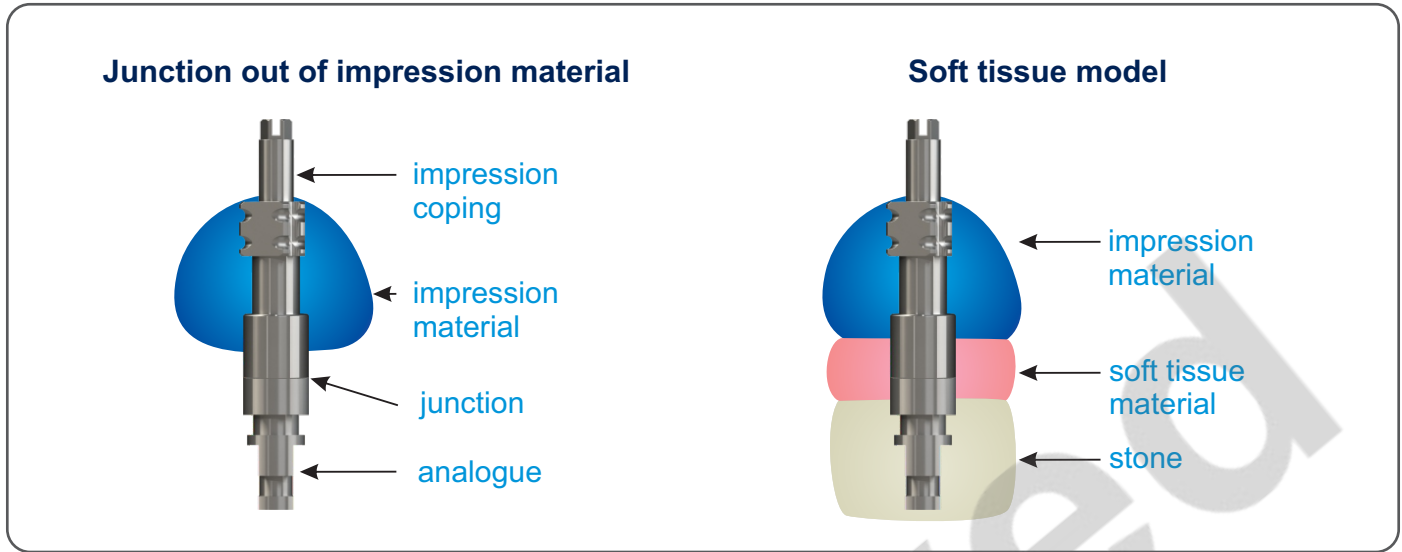

1. Make a working model with removable soft tissue material around the analogues.
2. Use either non-engaging Gold Abutments or non-engaging Passive Abutments (Refer to IFU CAT-8012 and CAT-8005,) to manufacture the prosthesis.
3. Complete the prosthesis with acrylic or ceramic (as applicable).

Second clinical procedure:

Attach the prosthesis to the Compact Conical Abutment: Place and tighten the restoration screw. Verify the correct seating of the restoration using radiographic imaging. Tighten the restoration using a manual torque wrench to 10-15Ncm.

1. Close screw access hole.
2. Cement final prosthesis if applicable.

Materials:

Compact Conical Abutment: Grade 5 Titanium
 Abutment screws: Titanium alloy Ti-90%, Al-6%, V-4% or Gold Alloy Au-61%, Ag-16.5%, Pt-13.5%, Cu -9%

Magnetic Resonance (MR) safety information:

This device has not been evaluated for safety and compatibility in the MR environment. It has not been tested for heating, migration or image artefact in the MR environment. The safety of this device in the MR environment is unknown. Scanning a patient who has this device may result in patient injury.

Storage, Cleaning & Sterilization

These abutments are supplied sterile and intended for single use prior to the expiration date (see packaging label). Sterility is assured unless the container or seal is damaged or opened. Do not re-sterilize or autoclave these components. The product must be stored in a dry place in the original packaging at room temperature and not exposed to direct sunlight. Incorrect storage may influence device characteristics.

Disposal:

Disposal of the device and its packaging shall follow local regulations and environmental requirements, taking different contamination levels into account.

Symbols & Warnings

 Manufacturer: Southern Implants 1 Albert Rd, P.O. Box 605 IRENE, 0062, South Africa. Tel: +27 12 667 1046 Fax: +27 12 667 1029	CE 0086 CE	Rx ONLY Prescription device *	STERILE R Sterilization using Irradiation	 Non-sterile	 Caution	 Consult instruction for use	 Use by date (mm-yy)	 Do not reuse	 Do not Re-sterilize	LOT Batch code	 Do not use if package is damaged
* Prescription device: Rx only. Caution: Federal law restricts this device to sale by or on the order of a licensed physician or dentist.						Canada license exemption: Please note that not all products may have been licensed in accordance with Canadian law.					
All rights reserved. Southern Implants, the Southern Implants logotype and all other trademarks used in this document are, if nothing else is stated or is evident from the context in a certain case, trademarks of Southern Implants. Product images in this folder are for illustration purposes only and do not necessarily represent the product accurately to scale.											

For Technical Assistance or additional product literature, please contact Southern Implants.

Southern Implants (Pty)Ltd

P.O Box 605
Irene, 0062
South Africa

Manufacturer:**Southern Implants (Pty)Ltd**

1 Albert road
Irene, 0062

Tel: +27 12 6671046

e-mail: info@southernimplants.com

European Representative:

Building 3, Chiswick Park
566 Chiswick High Road
Chiswick
London W4 5YA

United Kingdom

Tel: 0044 208 998 0063

Fax: 0044 208 997 0580

Americas/Asia

225 Chimney Corner Lane
Suite 3011
Florida 33458

USA

Tel: 0056 1472 0990

Fax: 0056 1472 8401

Disclaimer of liability:

This product is part of the Southern Implants product range and should only be used with the associated original products and according to the recommendations as in the individual product catalogues. The user of this product has to study the development of the Southern Implants product range and take full responsibility for the correct indications and use of this product. Southern implants does not assume liability for damage due to incorrect use. Please note that some Southern Implants products may not be cleared or released for sale in all markets.