



Intended Use

Southern Implants tapered drills and bone taps are intended to be used to prepare the osteotomy for implant placement. The tapered drills and MAX bone taps are implant length specific.

Description

Southern Implants tapered drills and bone taps are as described in Table 1 and Table 2, respectively. These re-usable drills are made of stainless steel or Titanium Alloy (Grade 5) and some are coated with Titanium Nitride (TiN) or Aluminium Titanium Nitrate (AlTiN), refer to the tables below for specific details.

Table 1. Tapered drills

Drill code	Material	Coating (if any)	Final recommended tapered drill for implant placement of:	Bone Condition (Soft, Medium, Dense)	Drill Identification	
					Laser marked	Colour ID
External Hex						
D-30TP-XX	Titanium Alloy		Ø3.0mm External Hex implants	Dense	✓	
D-33TP-XX	Titanium Alloy		Ø3.4mm External Hex implants	Medium to Dense	✓	■
D-33TP-XX-L	Titanium Alloy		Ø3.4mm External Hex implants, Longer shaft drill	Medium to Dense	✓	■
D-40E-04F	Titanium Alloy		Ø4.0mm IET/IETi External Hex implants	Medium to Dense	✓	
D-40TP-XX	Stainless Steel		Ø4mm External Hex implants	Medium to Dense	✓	■
D-40TP-XX-L	Titanium Alloy		Ø4.0mm External Hex implants, Longer shaft drill	Medium to Dense	✓	■
D-50TP-XX	Stainless Steel		Ø5.0mm External Hex implants	Medium to Dense	✓	■
D-50TP-XX-L	Titanium Alloy		Ø5mm External Hex implants, Longer shaft drill	Medium to Dense	✓	■
D-60TP-XX	Stainless Steel		Ø6mm External Hex implants	Medium to Dense	✓	■
Dedicated Dense Bone Drills						
D-42TP-XX	Stainless Steel	TiN	Ø4.0mm External Hex implants	Dense	✓	■
D-52TP-XX	Stainless Steel	TiN	Ø5.0mm External Hex implants	Dense	✓	■
D-62TP-XX	Stainless Steel	TiN	Ø6.0mm External Hex implants	Dense	✓	■
PROVATA (Internal Hex)						
D-40TP-XX	Stainless Steel		Ø4mm Provata implants	Medium to Dense	✓	■
D-40TP-XX-L	Titanium Alloy		Ø4.0mm Provata implants, Longer shaft drill	Medium to Dense	✓	■
D-50TP-XX	Stainless Steel		Ø5.0mm Provata implants,	Medium to Dense	✓	■
D-50TP-XX-L	Titanium Alloy		Ø5mm Provata implants, Longer shaft drill	Medium to Dense	✓	■

Images are for illustration purposes only and do not necessarily accurately represent the product. Not all products are cleared for sale in all countries.





Drill code	Material	Coating (if any)	Final recommended tapered drill for implant placement of:	Bone Condition (Soft, Medium, Dense)	Drill Identification	
					Laser marked	Colour ID
TRI-NEX						
Dedicated Soft Bone Drills						
DLS-35-XX	Titanium Alloy		Ø3.5mm TRI-NEX implant	Soft	✓	
DLS-43-XX	Titanium Alloy		Ø4.3mm TRI-NEX implant	Soft	✓	
DLS-50-XX	Titanium Alloy		Ø5mm TRI-NEX implant	Soft	✓	
DLS-60-XX	Titanium Alloy		Ø6mm TRI-NEX implant	Soft	✓	
Dedicated Drills						
D-L-35-XX	Stainless Steel		Ø3.5mm TRI-NEX implant	Medium to Dense	✓	
D-L-43-XX	Stainless Steel		Ø4.3mm TRI-NEX implant	Medium to Dense	✓	
D-L-50-XX	Stainless Steel		Ø5mm TRI-NEX implant	Medium to Dense	✓	
D-L-60-XX	Stainless Steel		Ø6mm TRI-NEX implant	Medium to Dense	✓	
DC (Deep Conical)						
D-DCT-30XX	Titanium Alloy	AlTiN	Ø3mm Deep conical implant	Medium to Dense	✓	
D-DCT-35XX	Titanium Alloy	AlTiN	Ø3.5 & 4mm Deep conical implant	Medium to Dense	✓	
D-DCT-40XX	Titanium Alloy	AlTiN	Ø4.0mm Deep conical implant	Medium to Dense	✓	
D-DCT-50XX	Titanium Alloy	AlTiN	Ø5.0mm Deep conical implant	Medium to Dense	✓	
M-series (Internal Hex)						
D-MT37XX	Titanium Alloy		Ø3.7mm Internal Hex implants	Medium to Dense	✓	
D-MT42XX	Titanium Alloy		Ø4.2mm Internal Hex implants	Medium to Dense	✓	
D-MT50XX	Titanium Alloy		Ø5mm Internal Hex implants	Medium to Dense	✓	
IT (Internal Octagon)						
D-4XXT	Stainless Steel		Ø4.0mm IT implants with Ø4.8 interface	Medium to Dense	✓	
D-5XXT	Stainless Steel		Ø5.0mm IT implants with Ø4.8 interface Ø5.0mm IT6 implants with Ø6.5mm interface	Medium to Dense	✓	
D-6XXT	Stainless Steel		Ø6.5mm IT6 implants with Ø6.5mm interface	Medium to Dense	✓	
MAX Implants (MAX, PROMAX, TRI-MAX, MAXIT)						
D-MAX6-X	Titanium Alloy		Ø6.0mm MAX External Hex implants Ø6.0mm MAX PROMAX implants	Medium to Dense	✓	
D-70TP-X	Titanium Alloy		Ø7.0mm MAX External Hex implants Ø7.0mm MAX PROMAX implants Ø7.0mm MAX TRI-MAX implants Ø7.0mm MAX MAXIT implants	Medium to Dense	✓	
D-70TP-X-L	Titanium Alloy		All Ø7.0mm MAX implants, Longer shaft drill			
D-80TP-X	Titanium Alloy		Ø8.0mm MAX External Hex implants Ø8.0mm MAX PROMAX implants Ø8.0mm MAX TRI-MAX implants Ø8.0mm MAX MAXIT implants	Medium to Dense	✓	
D-80TP-X-L	Titanium Alloy		All Ø8.0mm MAX implants, Longer shaft drill			
D-90TP-X	Titanium Alloy		Ø9.0mm MAX External Hex implants Ø9.0mm MAX PROMAX implants Ø9.0mm MAX TRI-MAX implants Ø9.0mm MAX MAXIT implants	Medium to Dense	✓	
D-90TP-X-L	Titanium Alloy		All Ø9.0mm MAX implants, Longer shaft drill			

Table 2. Bone taps

Tap drill code	Material	Final recommended tap drill for implant placement of:	Bone Condition (Soft, Medium, Dense)	Drill Identification
				Laser marked
External Hex				
D-TAP-IBNT	Titanium Alloy	Ø3.25mm External Hex implants	Dense	✓
D-TAP-IBT	Titanium Alloy	Ø4.0mm External Hex implants	Dense	✓
D-TAP-BAT	Titanium Alloy	Ø5.0mm External Hex implants	Dense	✓
D-TAP-BBBT	Titanium Alloy	Ø6.0mm External Hex implants	Dense	✓
PROVATA (Internal Hex)				
D-TAP-IBT	Titanium Alloy	Ø4.0mm PROVATA implants	Dense	✓
D-TAP-BAT	Titanium Alloy	Ø5.0mm PROVATA implants	Dense	✓
TRI-NEX				
D-TAP-L-35	Titanium Alloy	Ø3.5mm TRI-NEX implant	Dense	✓
D-TAP-L-43	Titanium Alloy	Ø4.3mm TRI-NEX implant	Dense	✓
D-TAP-L-50	Titanium Alloy	Ø5mm TRI-NEX implant	Dense	✓
D-TAP-L-60	Titanium Alloy	Ø6mm TRI-NEX implant	Dense	✓
IT (Internal Octagon)				
D-TAP-ITT4	Titanium Alloy	Ø4.0mm IT implants with Ø4.8 interface	Dense	✓
D-TAP-ITT5	Titanium Alloy	Ø5.0mm IT implants with Ø4.8 interface Ø5.0mm IT6 implants with Ø6.5mm interface	Dense	✓
D-TAP-ITT	Titanium Alloy	Ø6.5mm IT6 implants with Ø6.5mm interface	Dense	✓
MAX Implants (MAX, PROMAX, TRI-MAX, MAXIT)				
D-TAP-MAX6-X	Titanium Alloy	Ø6.0mm MAX External Hex implants Ø6.0mm PROMAX implants	Dense	✓
D-TAP-MAX7-X	Titanium Alloy	Ø7.0mm MAX External Hex implants Ø7.0mm MAX PROMAX implants Ø7.0mm MAX TRI-MAX implants Ø7.0mm MAX MAXIT implants	Dense	✓
D-TAP-MAX8-X	Titanium Alloy	Ø8.0mm MAX External Hex implants Ø8.0mm MAX PROMAX implants Ø8.0mm MAX TRI-MAX implants Ø8.0mm MAX MAXIT implants	Dense	✓
D-TAP-MAX9-X	Titanium Alloy	Ø9.0mm MAX External Hex implants Ø9.0mm MAX PROMAX implants Ø9.0mm MAX TRI-MAX implants Ø9.0mm MAX MAXIT implants	Dense	✓

Indications for use of Our implant systems:

Southern Implants' Dental Implants are intended to be implanted in the upper or lower jaw arches to provide support for fixed or removable dental prostheses in a single tooth, partially edentulous prostheses or full-arch prostheses. It further adds the option for immediate placement and function on single and splinted multiple unit restorations when good primary stability is achieved and with appropriate occlusal loading, to restore chewing function.

Indications for use of Our tapered drills and bone taps:

Southern Implants tapered drills are indicated for a step-wise drilling approach, when preparing an osteotomy, for tapered implants, in soft, normal or dense bone, by following the drill protocols as recommended in the product catalogues.

Southern Implants bone taps are indicated for pre-tapping a thread into the bone when preparing an osteotomy in dense bone, by following the drill protocols as recommended in the product catalogues, to aid in implant placement.

Contraindications

Do not use in patients:

- who are medically unfit for dental implant procedures (e.g. uncontrolled diabetes and untreated infection in nearby bone).
- who are allergic to or have hypersensitivity to pure Titanium, Titanium Alloy (Ti-6AL-4V), Aluminium Titanium Nitride (AlTiN) or stainless steel.
- where adequate numbers of implants cannot be placed to achieve full functional support for a prosthesis.

Warnings

- THESE INSTRUCTIONS ARE NOT INTENDED AS A SUBSTITUTE FOR ADEQUATE TRAINING.
- For the safe and effective use of dental implants it is strongly suggested that specialised training be undertaken, including hands-on training to learn proper technique, biomechanical requirements and radiographic evaluations.
- Responsibility for proper patient selection, adequate training, experience in the placement of implants, and providing appropriate information for informed consent rests with the practitioner. Improper technique can result in implant failure, damage to nerves/vessels and/or loss of supporting bone.
- The use of non-sterile items can lead to secondary infections of the tissue or transfer infectious diseases.
- Blunt drills may cause damage to the bone which could compromise osseointegration.

Cautions

- New and experienced implant users should undergo training before using a new system or attempting to do a new treatment method.
- Take special care when treating patients who have local or systemic factors that could affect the healing of the bone and soft tissue (e.g. patients that have had oro-facial radiotherapy, poor oral hygiene, patients on steroid therapy and smokers).
- Thorough screening of prospective implant candidates must be performed, including:
 - A comprehensive medical and dental history.
 - Visual and radiological inspection to determine adequate bone dimensions, anatomical landmarks, occlusal conditions, periodontal status, and adequacy of bone.
- Bruxism and unfavourable jaw relations must be taken into account.
- Proper pre-operative planning with a good team approach between well trained surgeons, restorative dentists and lab technicians is essential for successful implant treatment.
- Minimizing the trauma to the host tissue increases the potential for successful osseointegration.

During procedure

- Care must be taken that parts are not swallowed during any of the procedures thus, rubber-dam application is recommended when appropriate.

Post-procedure

- Regular patient follow-up, and proper oral hygiene are essential for favourable long-term results.

Clinical procedures

Case Planning:

A proper clinical and radiological evaluation must be done to determine the bone dimensions and bone quality. Ensure that all instruments and drills are in a good condition.

Surgical:

Southern Implants provides the user with different drill options, for placement of tapered implants, depending on the bone quality. Refer to Table 1 & Table 2 for more details together with the product catalogues.

The drill sizes are identified by different colour markings (paint on shaft) and/or laser markings on shaft.

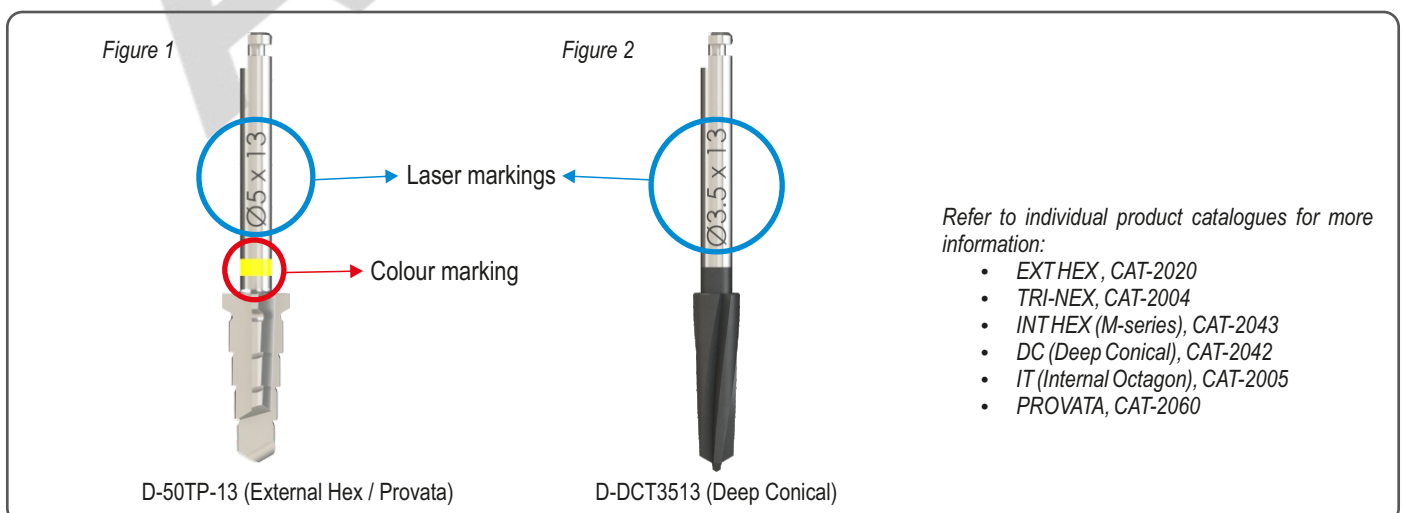

1. The tapered implants have dedicated tapered drills per implant length.
2. Tapered drills extend up to 1mm longer than the implant, when seated. Allow for this additional length when drilling near vital anatomical structures.
3. Drill at sufficient speed (800 rpm - 1200 rpm with tapered drills), with copious irrigation using sterile saline. An intermittent technique should be used to avoid overheating of the bone.
4. Use an up-and-down motion with the hand-piece, without stopping the motor. This will allow the irrigation to flush away bone debris.
5. During surgery, the clinician will be able to assess the bone quality and should use dense bone protocols when necessary to prepare the site. This is to avoid the implant getting stuck before it is properly seated in the osteotomy.
6. Preparing the site should further involve: making sure the drill reaches full depth and/or use of the optional bone tap to pre-tap the site. Tap at low speed (25rpm), with a maximum torque of 40 Ncm. Switch the hand-piece to reverse mode for tap removal.

Note: When a drill extension is used (I-DE-K / I-DE-G), care must be taken to ensure that the latch is fully engaged to prevent distortion. See Figure 3 & Figure 4 below.

- Drill extensions must **NOT** be used with Ø6mm and larger drills, use longer shaft drills instead.
- Drill extensions must **NOT** be used with Bone taps.

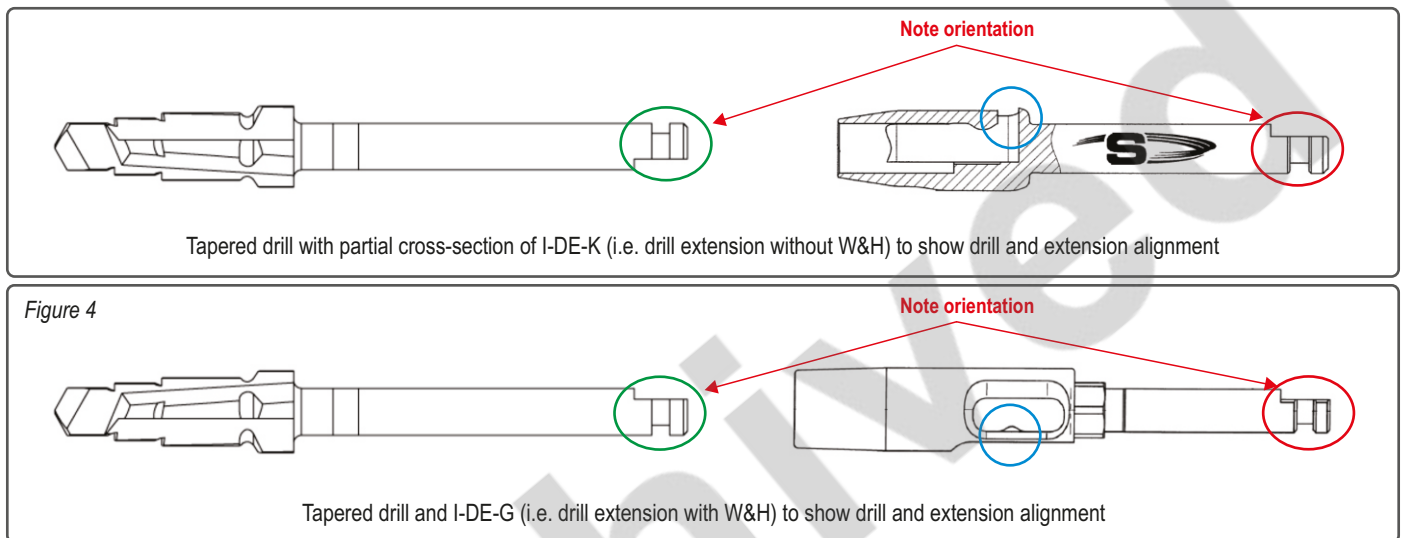

The orientations indicated in Figure 3 and Figure 4 ensure that the catch feature of the drill extension (circled in blue) slots into the latch groove of the drill (circled in green). This prevents the drill from sliding out of the drill extension.

Tapered drills can be used up to 20 times or when the cutting efficiency deteriorates, and bone taps up to 10 times or when the cutting efficiency deteriorates. It is recommended to maintain a log of these drills, recording the number of uses (Please refer to CAT-2067-00 External Hex Reusable Drill Usage Guide, CAT-2071-00 TRI-NEX Drill Usage Guide, CAT-2072-00 MAX Drill Usage Guide, CAT-2059-01 Internal Hex Drill Usage Guide, CAT-2054-01 Deep Conical Drill Usage Guide). Prior to re-processing these components, it should be thoroughly inspected and tested to determine its suitability for re-use.

Materials

Drills: Stainless Steel, or Titanium Alloy (Ti-6AL-4V)
 Drill Coating: None, or Titanium Nitride (TiN), or Aluminium Titanium Nitride (AlTiN)

Magnetic Resonance (MR) safety information

This device has not been evaluated for safety and compatibility in the MR environment. It has not been tested for heating, migration or image artefact in the MR environment. The safety of this device in the MR environment is unknown. Scanning a patient who has this device may result in patient injury.

Storage, Cleaning & Sterilization

Southern Implants tapered drills and bone taps are supplied sterile. The product must be stored in a dry place at room temperature and not exposed to direct sunlight. Incorrect storage may influence device characteristics. Do not use if original package is damaged. Sterility is assured unless the original packaging is damaged or opened.

If re-use seems fit:













- **Containment:** As soon as practically possible, remove all visible residue after use (bone, blood or tissue), by immersing the instrument in cold water (Dried soil is difficult to remove).
- **Pre-Cleaning:** Rinse with lukewarm water for 3 minutes, and remove hardened debris with a soft nylon brush. Avoid mechanical damage during cleaning.
- **Manual Cleaning or Automated Cleaning:** Prepare an ultrasonic bath with suitable detergent, sonicate for 20 minutes (Alternative methods can be used if proven by the end user). Rinse with purified / sterile water. Load devices into a thermo-disinfector. Run the cleaning and disinfection cycle, followed by the drying cycle.
Note: Always follow the instructions for use of the manufacturers of cleaning agents and disinfectants.
- **Drying:** Dry the instruments with filtered compressed air or single use lint free wipes. Pack the instruments as quickly as possible after removal. If additional drying is necessary, dry in a clean location.
Note: Moisture on drills can cause corrosion and deterioration of the cutting edges.
- **Inspection:** Do a visual inspection of the items to check for any damage/s.
- **Packaging:** Use the correct packaging material as indicated for steam sterilization to ensure sterility is maintained. Double packaging is recommended.

- **Pre-vacuum sterilization:** Steam sterilize the components at 132°C (270°F), at 180 - 220 kPa for 4 minutes, or at 135°C (275°F), at 180 - 220 kPa for 3 minutes. Dry for at least 20 minutes in the chamber.
Note: Only an FDA or appropriate regulatory authority approved wrap or pouch for steam sterilization must be used. It is the responsibility of the user to establish whether or not their sterilizer is approved by an appropriate regulatory authority to meet recommended parameters.
- **Storage:** Maintain packaging integrity to ensure sterility in storage. Packaging should be dry before storage to avoid corrosion and degradation of cutting edges. Device should be stored at room temperature and not exposed to direct sunlight.

Disposal

Disposal of the device and its packaging shall follow local regulations and environmental requirements, taking different contamination levels into account.

Symbols & Warnings

 Manufacturer: Southern Implants 1 Albert Rd, P.O. Box 605 IRENE, 0062, South Africa. Tel: +27 12 667 1046 Fax: +27 12 667 1029	 	 Prescription device *	 Sterilization using Irradiation	 Non-sterile	 Caution	 Consult instruction for use	 Use by date (mm-yy)	 Do not reuse	 Do not Re-sterilize	 Batch code	 Do not use if package is damaged
	* Prescription device: Rx only. Caution: Federal law restricts this device to sale by or on the order of a licensed physician or dentist.						Canada license exemption: Please note that not all products may have been licensed in accordance with Canadian law.				
All rights reserved. Southern Implants, the Southern Implants logotype and all other trademarks used in this document are, if nothing else is stated or is evident from the context in a certain case, trademarks of Southern Implants. Product images in this folder are for illustration purposes only and do not necessarily represent the product accurately to scale.											

Disclaimer of liability:

This product is part of the Southern Implants product range and should only be used with the associated original products and according to the recommendations as in the individual product catalogues. The user of this product has to study the development of the Southern Implants product range and take full responsibility for the correct indications and use of this product. Southern implants does not assume liability for damage due to incorrect use. Please note that some Southern Implants products may not be cleared or released for sale in all markets.

For Technical Assistance or additional product literature, please contact Southern Implants:

Southern Implants (Pty)Ltd

P.O Box 605
Irene, 0062
South Africa

Manufacturer:
Southern Implants (Pty)Ltd
1 Albert road
Irene, 0062

Tel: +27 12 6671046
e-mail: info@southernimplants.com

European Representative:

Building 3, Chiswick Park
566 Chiswick High Road
Chiswick
London W4 5YA
United Kingdom

Americas/Asia

225 Chimney Corner Lane
Suite 3011
Florida 33458
USA